



350 S. St. Charles St. Jasper, In. 47546
Ph. 812.482.2932 Fax 812.634.6632
www.ridetech.com

Part # 11220199
64-67 GM "A" Body Level 1 Air Suspension System

Front Components:

- | | | |
|---|----------|---|
| 1 | 11221099 | Front CoolRide Kit for Stock Lower Arms |
| 1 | 11220500 | Black Series Front Shock Kit w/ Mounts |

Rear Components:

- | | | |
|---|----------|--------------------------|
| 1 | 11224099 | Rear CoolRide Kit |
| 1 | 11220700 | Black Series Rear Shocks |

Compressor System:

- | | | |
|---|----------|---|
| 1 | 30154000 | 3 gallon RidePro Compressor Kit (Analog Gauges) |
|---|----------|---|



350 S. St. Charles St. Jasper, In. 47546
Ph. 812.482.2932 Fax 812.634.6632
www.ridetech.com

Part # 11221099
64-72 GM "A" Body Front CoolRide Kit

Components:

2	90006781	Front air spring – 267c
1	90000370	Driver side lower air spring plate
1	90000371	Passenger side lower front plate
2	90000372	Upper air spring mount

Hardware:

2	99435001	7/16" x 6" stud	Upper air spring mount to frame
2	99433002	7/16" SAE flat washer	Upper air spring mount to frame
2	99432001	7/16" USS Nylok	Upper air spring mount to frame
8	99372002	3/8" USS Nylok	Air spring to upper mount / lower plate to arm
2	99371001	3/8" x 3/4" USS bolt	Air spring to lower mount
4	99371004	3/8" x 1 1/4" USS bolt	Lower plat to arm
2	99373005	3/8" lock washer	Air spring to lower mount
14	99373003	3/8" SAE flat washer	Air spring mounts

COOLRiDE[®]

by Air Ride Technologies

Installation Instructions

1. Raise the vehicle to a safe and comfortable working height with the suspension hanging freely.
2. Remove the coil spring and shock absorbers. Refer to the factory service manual for proper disassembly procedures.



3. Apply thread sealant to the air fitting and screw it into the top of the air spring.

4. Place the upper cup bracket on top of the air spring and fasten with two 3/8" nylok nuts and flat washers. Thread the 7/16" stud into the nut in the bottom of the cup.

5. Place the lower air spring bracket on the lower control arm, the large hole in the bracket will align with the sway bar hole on the lower arm.

6. The inner two holes must be drilled with a 3/8" bit. Fasten with two 3/8 bolts, Nylok nuts and flat washers.



7. Place the air spring assembly into the coil spring pocket with the stud sticking through the factory shock hole in the frame.

8. Mark the outside of the coil spring pocket where the air spring rubs. Remove the air spring and trim the pocket, a die grind with a cutoff wheel works well.

9. Reinstall the air spring assembly (the air line can be routed at this time) and secure with a 7/16" Nylok nut and flat washer on top of the frame.



11. Ride height on this air spring is approximately 5" tall. This may vary to driver preference.

ridetech
Air Ride Technologies



350 S. St. Charles St. Jasper, In. 47546
Ph. 812.482.2932 Fax 812.634.6632
www.ridetech.com

Part # 11220500
64-72 GM "A" Body Front Black Series Shock Kit
For Use w/ CoolRide

Components:

2	20000009	Black Series shocks – Eye/Eye
2	90001966	Shock sleeve
2	90000011	Weld-on upper shock bracket
2	90000034	Lower shock bracket

Hardware:

4	99501003	1/2" x 2 1/2" USS bolt	Shock to upper bracket
4	99502001	1/2" USS Nylok nut	Shock to upper bracket
2	99371004	3/8" x 1 1/4" USS bolt	Lower bracket to arm
2	99372002	3/8" USS Nylok nut	Lower bracket to arm
4	99373003	3/8" SAE flat washer	Lower bracket to arm

COOLRiDE[®]

by Air Ride Technologies

Installation Instructions



1. The upper shock mount must be welded to the frame. It may need to be cut down to match the stroke of the air spring and suspension. Make sure that when the suspension is fully compressed that the shock is about 1/4" from being fully compressed.
2. Tack weld the mount during initial fitment. The lower mount will be installed right behind the steer stop on the lower control arm.
3. Check to make sure the shock does not bottom out when the suspension is fully compressed. If the shock bottoms out it could damage the shock or shock mounts. Also check turning radius with the wheel. Once the final location is determined fully weld the upper mount to the frame.



Air Ride Technologies

350 S. St. Charles St. Jasper, In. 47546

Ph. 812.482.2932 Fax 812.634.6632

www.ridetech.com

Part # 11224099
64-72 GM "A" Body Rear CoolRide Kit

Components:

- | | | |
|---|----------|---|
| 2 | 90002018 | 91mm rolling sleeve air spring |
| 2 | 90002284 | Large cotter pin |
| 2 | 90000504 | Stud for cotter pin (screws into top of air spring) |
| 2 | 90000709 | Upper spring retainer washer (4" o.d. x .75" i.d.) |
| 2 | 90000291 | Lower spring retainer washer (2.5" o.d. x .5" i.d.) |
| 2 | 90000548 | Large lower air spring roll plate |

Hardware:

- | | | | |
|---|----------|----------------------|--------------------|
| 2 | 99371003 | 3/8" x 1" USS bolt | Air spring to axle |
| 2 | 99373003 | 3/8" SAE flat washer | Air spring to axle |
| 2 | 99373005 | 3/8" lock washer | Air spring to axle |

STRONGARMS™

by Air Ride Technologies

Installation Instructions

1. Raise and support vehicle at a safe and comfortable working height.
2. Support the axle then remove coil spring and shock. Refer to service manual for proper disassembly procedure. Installing one side at a time will make the installation easier.



3. Apply thread sealant to a 90 degree air fitting and screw it into the top of the air spring.
4. Screw the mounting pin into top of the air spring.



5. Place the 4" diameter washer on top of the frame, above the coil spring pocket. Raise the air spring up to the spring pocket with the pin sticking through the washer. Secure with the large cotter key.



6. Place the large lower air spring plate over the lower coil spring retainer.

7. Pull the piston down out of the air spring and seat it on the lower coil spring retainer. The center hub in the piston should fit inside the retainer.

8. Some retainers may require trimming to allow the air spring piston to slide into the retainer.



9. Secure the air spring to the axle using a 3/8" x 1" bolt, lock washer, flat washer, and the 2 1/2" washer.

10. Inflate the air spring and check air spring clearance. **If the spring is allowed to rub on anything it will cause failure, this is not a warrantable situation.**

14. This system will retain the factory bump stop.

15. Driving height on this air spring is approximately 8.5" tall, but may slightly vary to driver preference.



350 S. St. Charles St. Jasper, In. 47546
Ph. 812.482.2932 Fax 812.634.6632
www.ridetech.com

Part # 11220700
64-72 GM "A" Body Black Series Rear Shock Kit

Components:

- 2 20000008 Black Series rear shock – eye/T-bar
- 2 MON33082 hardware kit

Hardware:

- | | | | |
|---|----------|-----------------------|----------------|
| 4 | 99311001 | 5/16" x 1" USS bolt | Shock to frame |
| 8 | 99313002 | 5/16" SAE flat washer | Shock to frame |
| 4 | 99312003 | 5/16" USS Nylok nut | Shock to frame |

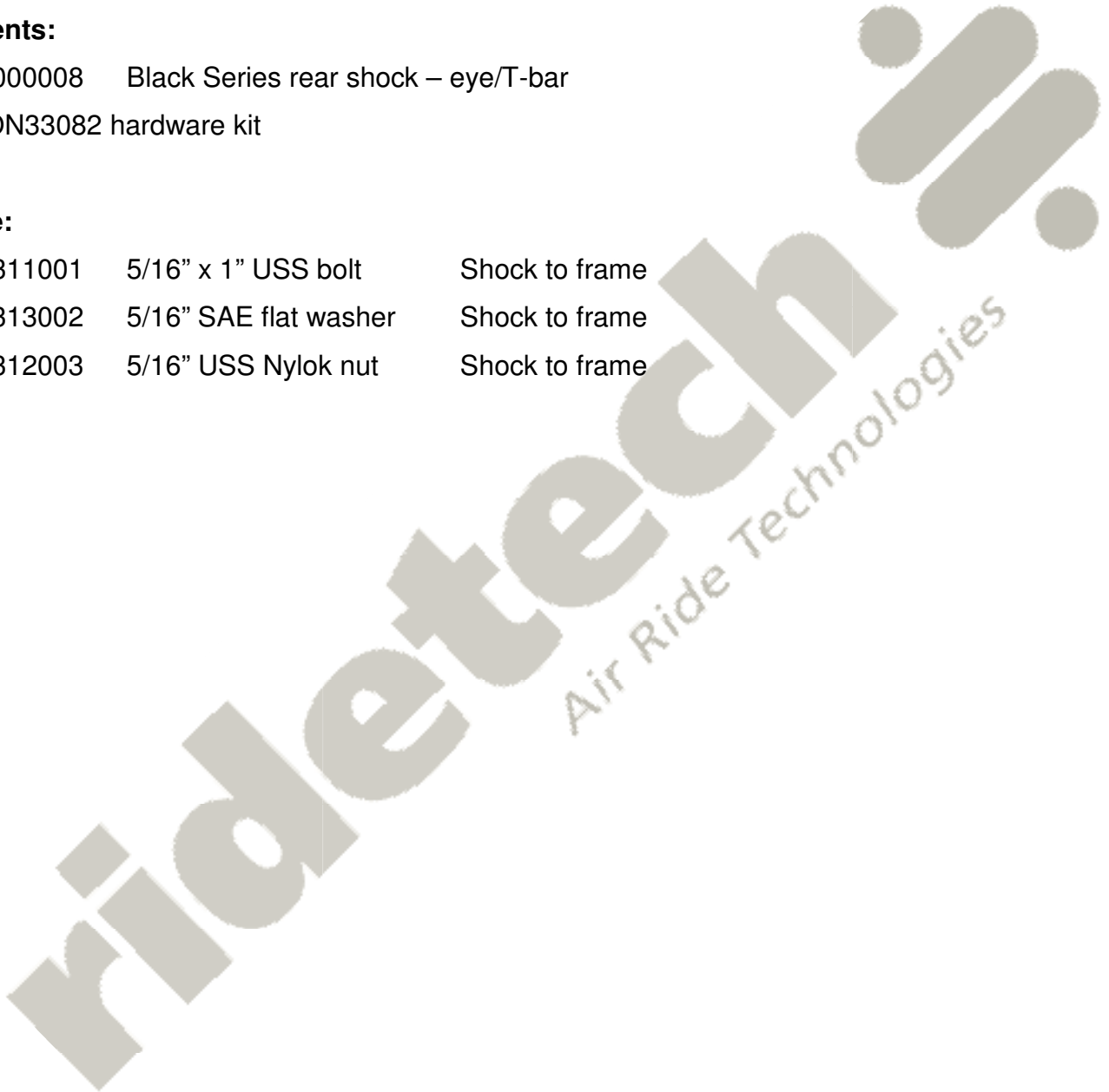

Installation Instructions



1. Attach the upper T-bar to the frame in the oem location using the supplied 5/16 x 1" USS bolts, washers and Nylok nuts.



2. Attach the shock to the axle using the new cantilever pin supplied.



350 S. St. Charles St. Jasper, In. 47546
Ph. 812.482.2932 Fax 812.634.6632
www.ridetech.com

Part # 30154000
4000 Series RidePro 4 Way Compressor System
3 Gallon Tank – Analog Gauges

Components:

- 1 31920002 Thomas 327 Compressor
- 1 31194000 RidePro 4 Way analog control panel with rocker switches (Black Face)
- 1 31913100 3 gallon aluminum tank
- 1 31934001 RidePro 4 Way valve block
- 1 31980005 Pressure switch – 135 On / 150 Off

Wiring:

- 1 90001924 Fuse holder
- 1 90001922 20 Amp fuse
- 2 31900036 Wiring harness - Control panel to valve

Airline & Fittings:

- 2 31940002 1/4" DOT airline - 30 ft. roll - valve block to gauges
- 2 31940000 1/8" DOT airline - 25 ft. roll - valve block to gauges
- 1 31952150 1/8"npt x 1/4" tube female straight - compressor
- 1 31957003 2" Brass Nipple - compressor
- 6 31954201 1/4" npt x 1/4" tube Elbow airline fitting
- 7 31954000 1/4" npt x 1/4" tube Straight airline fitting
- 4 31952000 1/8" npt x 1/8" tube Straight fitting - manifold to gauge fitting
- 1 31957004 1/4" npt plug - plug unused supply port



350 S. St. Charles St. Jasper, In. 47546

Ph. 812.482.2932 Fax 812.634.6632

www.ridetech.com

ARC4000 Compressor System Instructions

These are some general guidelines to follow when installing your new RidePro air control system. Depending on the vehicle there are many different ways to plumb the system. Start out by planning a lay out of where you want everything to be mounted. Typically we try to keep the compressor, solenoids, tank, and sending units in a central location, but they can be separated to suit your needs.

Mounting the Compressor/ Pressure Switch

- **Remove the negative battery cable before beginning installation.**
- All of our compressors are sealed for moisture and dust resistance so they can be mounted anywhere on the vehicle. Although it is best to mount it in a place out of direct contact with rain and snow. It is OK to mount it underneath the vehicle but keep it inside the frame rails away from water and debris thrown off the tire.
- This is a dry compressor; therefore it is maintenance free and can be mounted in any position.
- It is best if mounted to something solid to reduce vibration and noise. If mounting it to sheet metal or the bed of a truck, use sound deadening material between the compressor and the mounting surface.
- Use the rubber grommets supplied on the feet of the compressor to reduce vibration.
- A template is supplied to aid in drilling the holes. Check template with compressor before drilling the holes.
- Apply thread sealant to the pressure switch and compressor T and screw into the tank.
- One spade of the pressure switch will connect to power the other to the red wire on the compressor.

Mounting the Air Tank

- The air tank can be mounted anywhere on the vehicle in any position.
- A template is supplied to aid in drilling the holes. Check the template with the tank before drilling the holes.
- If your air system is used frequently you may want to remove the tank once a season to drain any excessive accumulation of water.

Mounting the RidePro Air Valves

- The valves, like the compressor, are sealed and can be mounted in the same locations. Although if the vehicle will be exposed to freezing temperatures it is a good idea to mount them in the engine bay if possible to reduce the possibility of freezing.
- They can be mounted in any position.
- Mount the valves higher than the tank to avoid moisture build up. This could cause the air pressure sensors to give a faulty reading.
- Attach the ground strap to a good, clean ground (preferably the frame).
- The exhaust port will be left open.
- The valve is held closed with the pressure in the tank. If tank pressure drops below air spring pressure they will equalize deflating all 4 air springs.

Wiring Harness

- The red wire on the harness will connect to 12 v.
- The gray wire will then supply the gauge light 12v. Or the gauge light can be powered with illumination.

Routing the Airline and Fittings

- Make all airline cuts with a razor or tubing cutter. It must be clean and straight or it will not seal.
- All fittings are DOT approved push-to-connect style. They are very simple to use and are reusable. Firmly push the airline into the fitting to attach. To release the airline pull the collar on the fitting back towards the fitting and pull the airline out.
- Use thread sealant on all fittings.
- Do not over tighten the fittings. This could result in breaking the fitting or damaging the air spring.
- All of our airlines are DOT approved so they are very strong. But keep them away from any sharp edges. Also when passing through a hole in the frame use a grommet.
- Keep away from intense heat including mufflers and exhaust manifolds.
- Use zip ties or other fasteners to secure the airline.

ARC4000

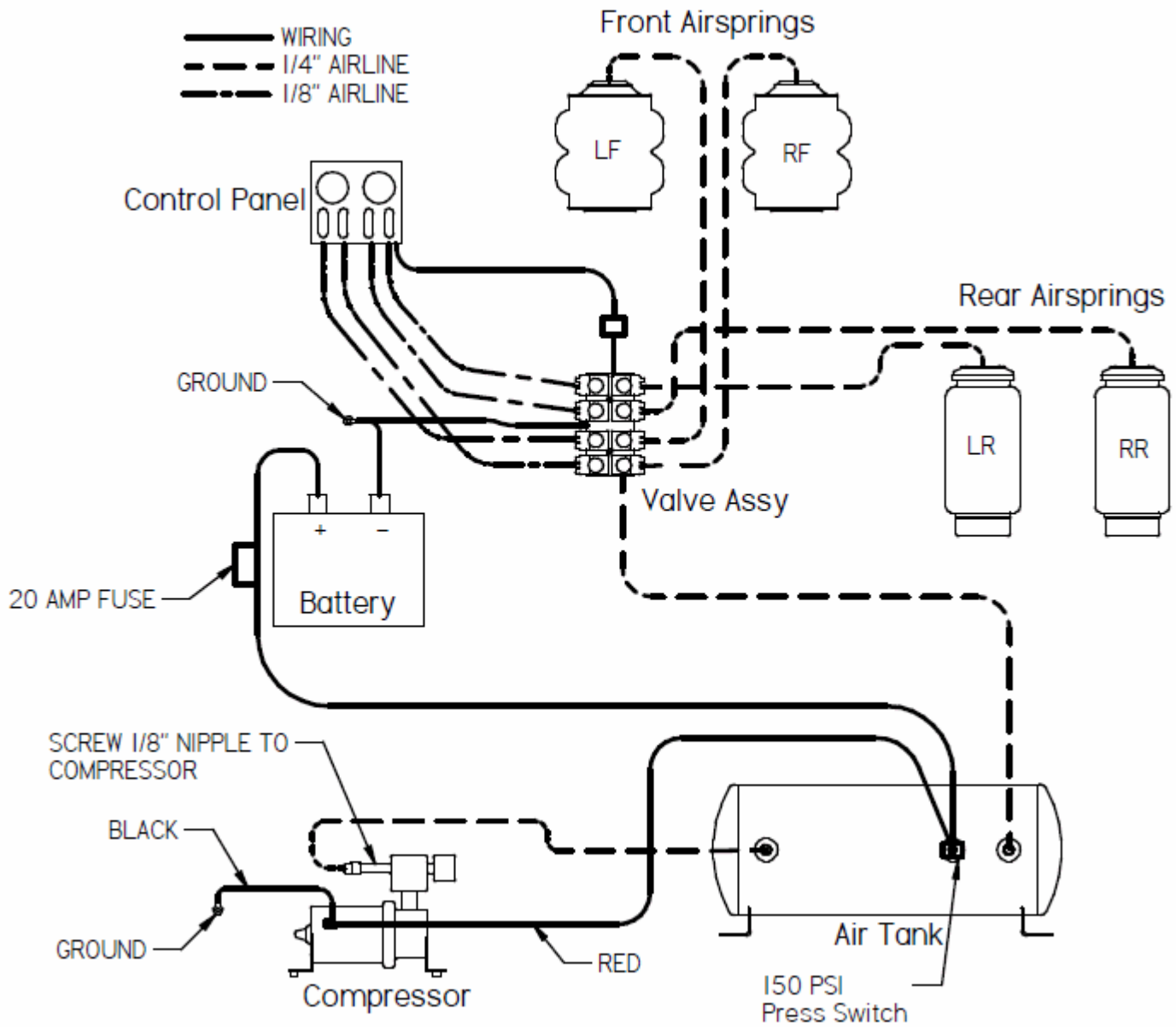

Wiring at control panel:

Gray connects to gauge light

Red connects to "key on" power at fuse box